

# Grass Dance Overview

By Andy Bess

## Intro:

The purpose of this paper is to provide an up-dated guide to New Native American Hobbyist. This is meant only to be a guide and not a Bible, as there are a lot of different ways and opinions on how to do things. The First thing we should always remember, as Native American Hobbyist, is that we are mimicking an on-going, living culture and we should be careful not to offend the Native American people or do things that they wouldn't. For that reason our motto should be "Emulate not Innovate". Grass Dancing is a Northern Plains Dance, therefore we should try to pattern our outfits and dancing style from Northern Plains Native Americans. Being careful not to copy but trying to develop our own unique set of dance clothes that are made within the guidelines of correct style, materials and decorations.

## Main parts:

**SHIRT OR CAPE:** Most Native Americans will wear a western style shirt, but I think a cape with a matching tee shirt is more practical. Because once you put fringe on a shirt and it becomes soaked with sweat it is hard to wash. And if you are not fully-grown, a cape can be made a little big, for growth. The front and back of the cape can be different shapes or the same. With the "V", "W" or "U" being most common. The cape/shirt should be made of solid color material, heavy enough to not sag from the weight of the fringe, but not stiff, cotton broadcloth is good. The fringe is usually sewn at the edge of the cape and extends to the elbows, usually about 12" to 14" long. The most popular fringe is white and made from yarn. But can also be made of ribbons or chainette fringe. Chainette is an older style. Small amounts of colored fringe are sometimes added. If using a shirt, the fringe is sewn at the shoulders extending down the back and front in the above shapes. The cape/shirt can be decorated with beadwork, ribbon work or appliqué along the fringe line or back center. Long strips of ribbons can be fastened with conchos or curtain rings to add more color and movement.

**PANTS:** The pants can be made of the same material and color as the cape/shirt or a pair of sport pants of a matching color. If making the pants you will need to buy a pattern for sport or pullover pants. These usually have elastic at the waist and legs, but you don't have to put the elastic in the legs. Most pant cuffs tend to be more snug fitting than in the past and are sometimes decorated with ribbon. If buying the pants, they have to be made of heavy enough material so they won't sag from the weight of the fringe. Fringe 10" to 12" long is added to the lower part of the pant legs in "V" shapes or around the legs to make the entire outfit look bottom-heavy. Ribbon work or beadwork can be used along the fringe line.

**APRONS:** The aprons can also be made of the same material as the cape/shirt and can be shaped to match the front or back of the cape or be completely different. They usually have fringe along the sides and bottom, 10" to 12" long. The front apron is decorated to match the cape. While the back apron is one of the highlights of the costume, it should be about the same length as the front apron, but is heavily decorated with rows of ribbon either shaped in a "V", "W" or zigzag with the ends hanging past the sides down to the ankles. Ribbon can hang from the center of the design and from other points on the apron with curtain rings or conchos.

**SIDE TABS:** The side tabs can be made as part of the belt or separately. They can be made of the same material as the rest of the outfit, and decorated with rosettes, ribbon work or edged with ribbon or either partially or fully beaded, in any shape you wish. They can be as long or longer than the aprons and with the same length fringe.

## **Accessories:**

**CUFFS AND ARMBANDS:** Cuffs are worn with the outfit and can be made of the same material as the cape/shirt decorated with ribbon work, rosettes or full or partial beadwork. Fringe 8" to 10" is added to the outside edge. Fully beaded cuffs have brain tan fringe, while yarn is used for the others.

Armbands are not always worn and if they are, they don't have to match the cuffs. They can be loom beaded, lazy stitched or decorated with ribbon work. Armbands with notched ends are very popular. Some have long streamers of ribbon or beaded drops hanging from them.

**BELT:** The belt is about 4” to 6” wide, it can be made of cloth and decorated with ribbon work, lazy stitch or loom beadwork. Loom beadwork can be fastened to leather. The side tabs can be fastened to the belt. The belt is buckled, tied or snapped in the back.

**HARNESS:** Most harnesses you see now are fully beaded and are usually worn outside the belt. Typically, they match the belt and extend to just below the knees. I wouldn't worry about a harness for a while; this should be one of the last things you make. Instead you can wear a crow style loop necklace made from crow or disc beads.

**NECKWEAR:** Most dancers today wear a simple scarf or bandanna that usually contrasts in color with the shirt. They are held in place by a silver or wooden slide. Some dancers will also wear a choker with the scarf or bandanna, or by itself. In the past fully beaded collars and ties were often worn with the outfit.

**BELLS:** Large sheep bells are the most common however, large sleigh bells are becoming popular. The bells are only worn around the ankles and usually five or six are worn on each ankle. Imitation sheep wool is often worn as padding behind the bells to keep them from cutting the ankles. Angora goat anklets are often worn under the bells.

**MOCCASINS:** Fully beaded plains moccasins are the most popular, but until your feet have stopped growing, sport shoes are very comfortable to dance in and can be easily replaced. Canvas deck shoes can be painted to look like beadwork.

**HAND ITEMS:** Fans and scarves are what most dancers carry now, but in the past they also carried dance hoops, whistles, mirror boards and beaded dowels with feather drops. Some dancers don't carry any hand items.

## **Head gear:**

**ROACH:** A long, colorful roach is preferred and is worn on the top of the head, slightly forward of center and has a flat look (Northern style) because of a wider spreader.

**HEAD HARNESS:** The roach is often attached to the head by means of a head harness rather than tying it under the chin. This is a more comfortable way to wear a roach and it looks good with the outfit. Many dancers don't like to wear a head harness, but will wear a headband. Rows of beads can be attached to either to form loops under the eyes. Drops can be hung from each side. These can be loom beaded, curtain rings tied together, ribbon or a string of tile or necklace beads. A beaded medallion is frequently worn on the front of the headband or harness and sometimes a matching medallion is worn on each side where the drops are attached.

**ROACH SPREADER:** The spreader may be made from several different materials, such as: German silver, rawhide or fully beaded. The top has two imitation eagle feathers or two antennae made from springs or wire with a lot of spring to it. Several white fluffy feathers or eagle plumes (imitation) are attached to the top of the antennae. The feathers should appear to float like clouds when you dance.

**General Comments:** The aprons, side tabs and belt should be worn down around the hips rather than at the waist. This causes the outfit to sway much more than if worn at the waist. From the waist down there should be a bottom heavy appearance to the outfit.

## **Sources:**

**GRASS DANCE CLOTHES** by James Johnston in Singing Wire, March, April, May 1968

**GRASS DANCE COSTUME** by William K. Powers 1961

# Grass Dance Outfit Construction

By Andy Bess

## I. Planning:

1. Study tapes, photos, calendars, magazines, etc. Then make a decision on colors, design and accessories:
  - A. Long sleeved shirt, three-quarter sleeved shirt or cape?
  - B. Buy or make pants?
  - C. Type and color of fringe, one color or several?
  - D. Type and color of material?
  - E. Type and color of decorations?
2. Make a drawing of the entire outfit (see example #1) include:
  - A. Main parts; shirt/cape, pants, aprons, belt and side tabs.
  - B. Armbands and cuffs, if not beading.
  - C. Location of fringe, ribbon, beadwork, drops, etc.

## II. Collecting Materials:

1. Look in fabric stores, catalogs, Wal-mart and other retail stores.
  - A. Cotton broadcloth or other heavy weight material 45" or 60" wide.
    - a. If making cape, you will need about 2 2/3 yards of material, buy tee shirt to match.
    - b. If buying pants, you will to match material for cape or shirt.
    - c. If making pants, you will need about 2 1/3 yards of same material as cape or shirt.
    - d. If making shirt, look at pattern material requirement.
  - B. Buy patterns
    - a. A western shirt pattern.
    - b. A sport pant pattern.
    - c. Or Missouri River Grass Dance pattern.
  - C. Buy fringe materials
    - a. Yarn, red heart brand is good.
    - b. White shoe strings, the longer the better.
  - D. Buy ribbon for drops and/or decorations.
    - a. Conchos or curtain rings for ribbon drops.
    - b. Ribbon work strips for decorations.

### III. Construction:

1. If using Missouri River Grass Dance pattern skip part 2.
2. Make patterns for cape, aprons, side tabs, etc. out of newspaper.
  - A. When making cape use western shirt yoke pattern.
    - a. Lay pattern on newspaper and mark around yoke shoulders.
    - b. Then shape from shoulders seams to desired shape of cape.
    - c. Make the front chest length and extend the back to mid center.
  - B. If making shirt use western shirt pattern.
  - C. If making pants use sport pant pattern.
3. Cut material
  - A. Everything but the pants should be lined to help support the fringe.
  - B. So cut two of every shape, front apron, back apron, cape parts, etc.
4. Sew parts
  - A. Put right sides together and sew sides and bottom.
  - B. Turn inside out and iron.
  - C. Finish open ends appropriately, belt casings on aprons, turn edges in and sew for cape, side tabs, etc.
5. Decorate parts with ribbon work, beadwork, etc.
6. Cut fringe double the length and tie on shoe strings
  - A. Fringe Lengths
    - a. Cape or Shirt: 12” to 14”
    - b. Pants: 10” to 12”
    - c. Aprons: 10” to 12”
    - d. Cuffs: 8” to 10”
  - B. Use a lark head knot.
  - C. Sew fringe to shoe strings to give a flatter look.
  - D. Sew on outfit according to drawing.
7. Add multicolor ribbon drops for extra color.

### IV. Finish

1. Practice dancing with completed outfit on.
2. Make adjustments.

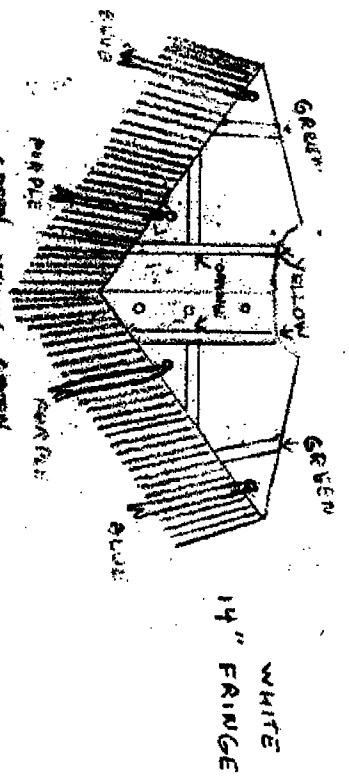

14" FRINGE  
WHITE

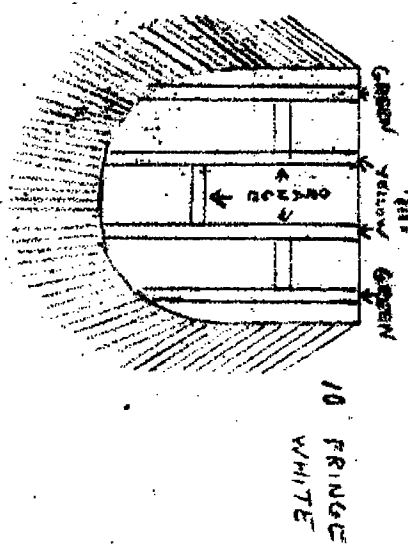

10" FRINGE  
WHITE

EXAMPLE #1

FRONT

SIDE

BACK

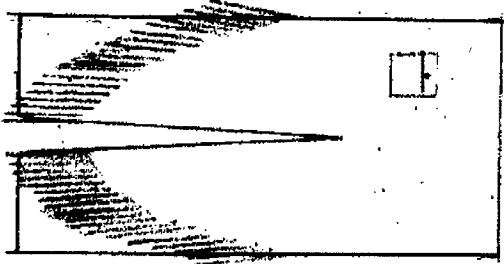

10" WHITE  
FRINGE

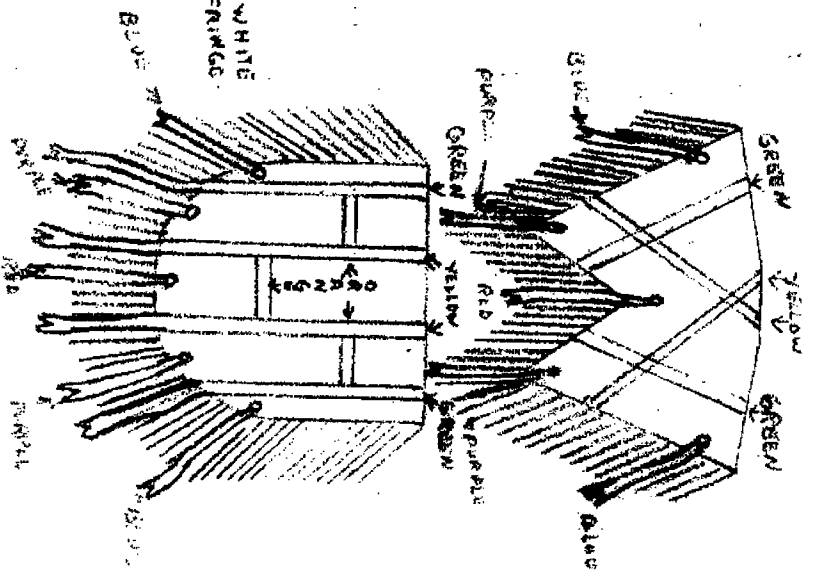
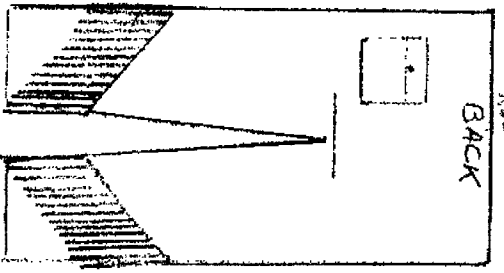
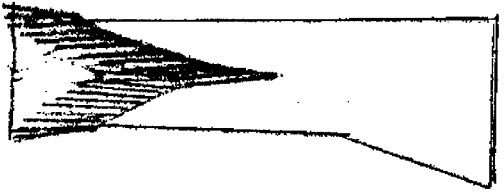

10" WHITE  
FRINGE

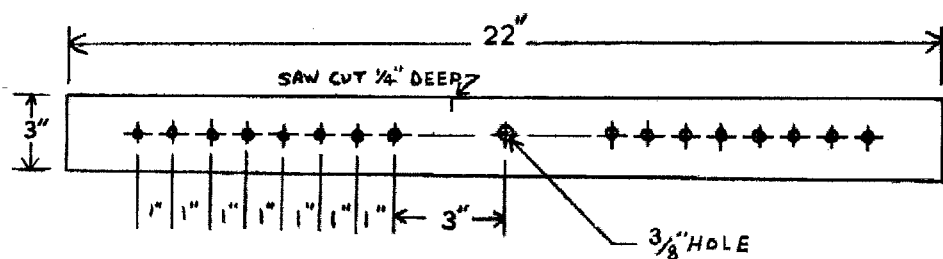
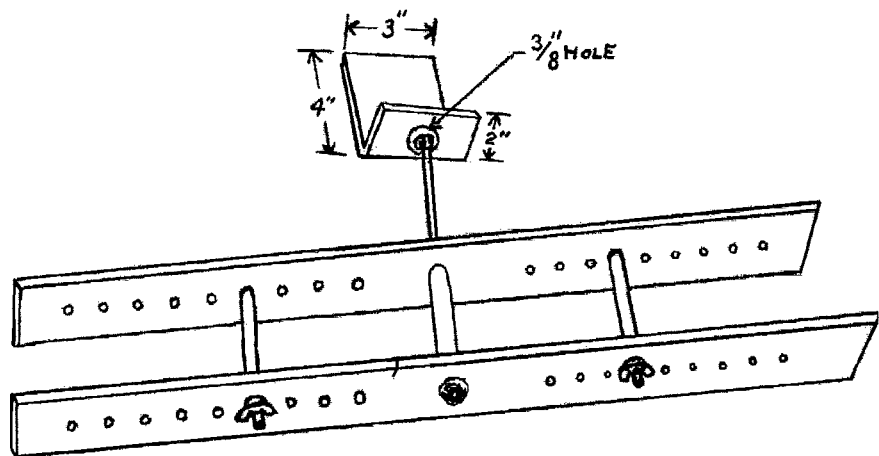

# YARN WINDER

## MATERIALS

- 2 - 1/4" x 4" CARRIDGE BOLTS
- 2 - 1/4" x 3" PIPE
- 2 - 1/4" FLAT WASHERS
- 2 - 1/4" WING NUTS
- 1 - 3/8" x 8" THREADED ROD
- 2 - 3/8" LOCK NUTS
- 2 - 3/8" NUTS
- 4 - 3/8" FLAT WASHERS
- 1 - 3/8" x 3" PIPE
- 2 - 1/4" x 3" x 22" PLASTIC OR WOOD
- 1 - 1/8" x 3" x 7" METAL STRIP WITH 2" BEND



# Yarn Tying Rack

